

<b>GL-01</b>	
EST. COST RANGE	\$15,000 - \$25,000
ESTIMATED LOADING REDUCTIONS (LBS/YR)	
TSS	1,175
TP	2.5
TN	7.9

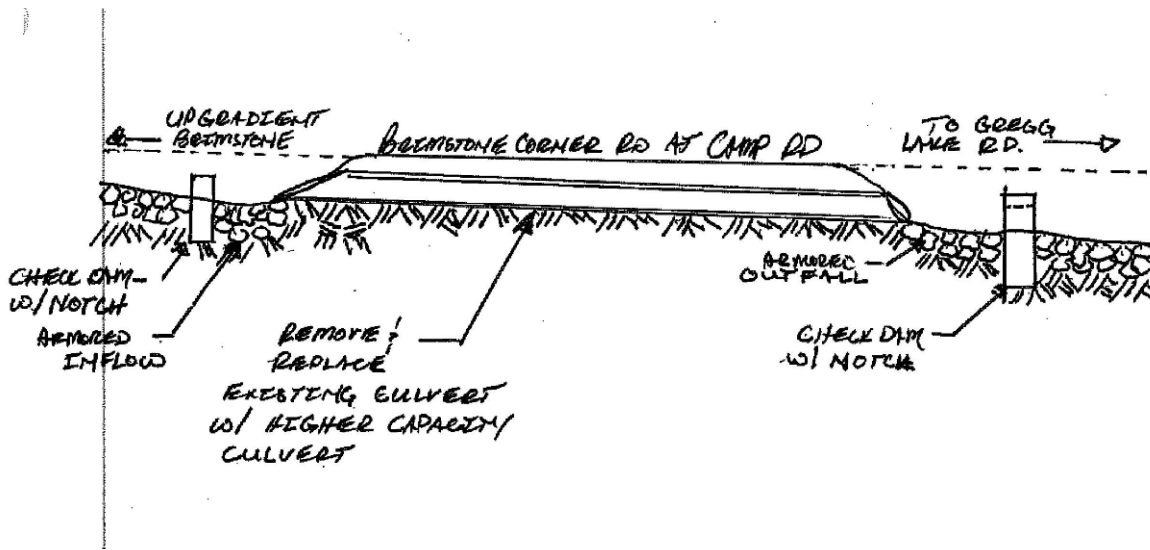

**CULVERT REPLACEMENT CROSS SECTION**

NOT TO SCALE

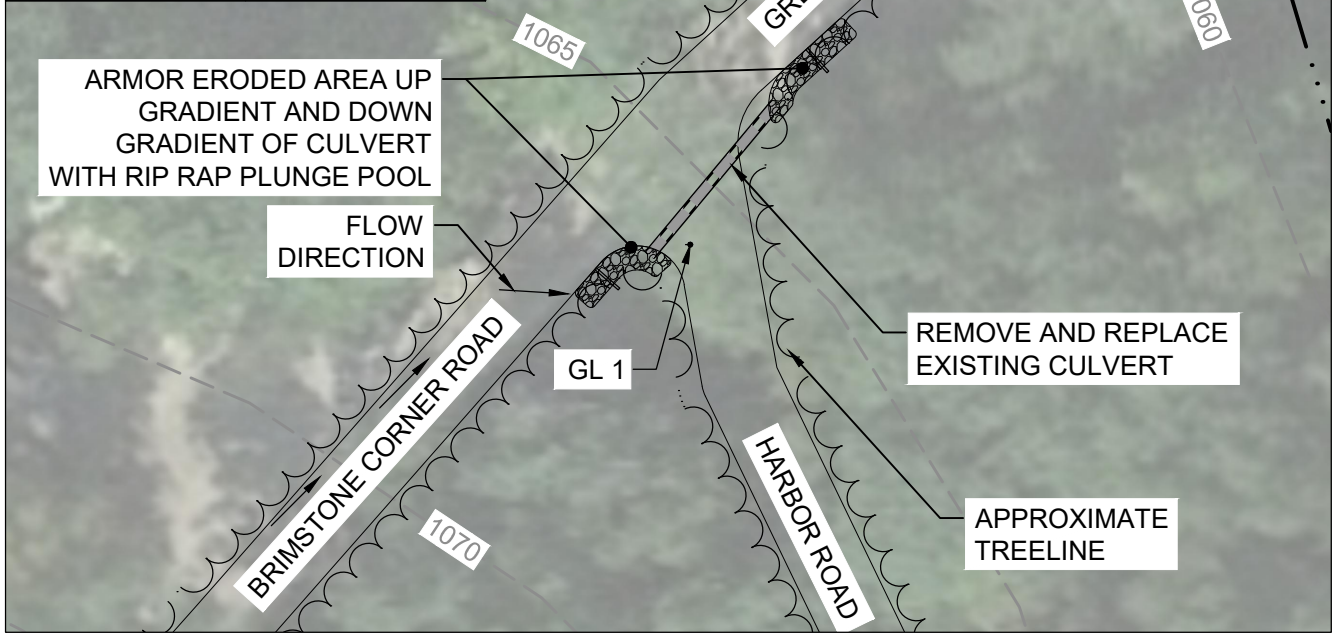
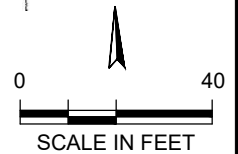

Project Number:  
**18116**

Sheet Number:  
**1 of 8**

Prepared For:  
Town of Antrim  
66 Main Street  
Antrim, NH 03440  
Phone: (603) 588-6785  
Fax: (603) 588-2969



Plan Set:  
**10% CONCEPTUAL BMP'S  
GREGG LAKE EROSION CONTROL  
ANTRIM, NEW HAMPSHIRE**

Plan Title:  
**BRIMSTONE CORNER ROAD AT  
GREGG LAKE ROAD (GL-01)**

**Horsley Witten Group, Inc.**  
Sustainable Environmental Solutions  
www.horsleywitten.com  
90 Route 6A  
Sandwich, MA 02563  
508-833-6600 voice  
508-833-3150 fax

Date: JULY 2019  
Designed By: GSG  
Drawn By: GSG  
Checked By: RB



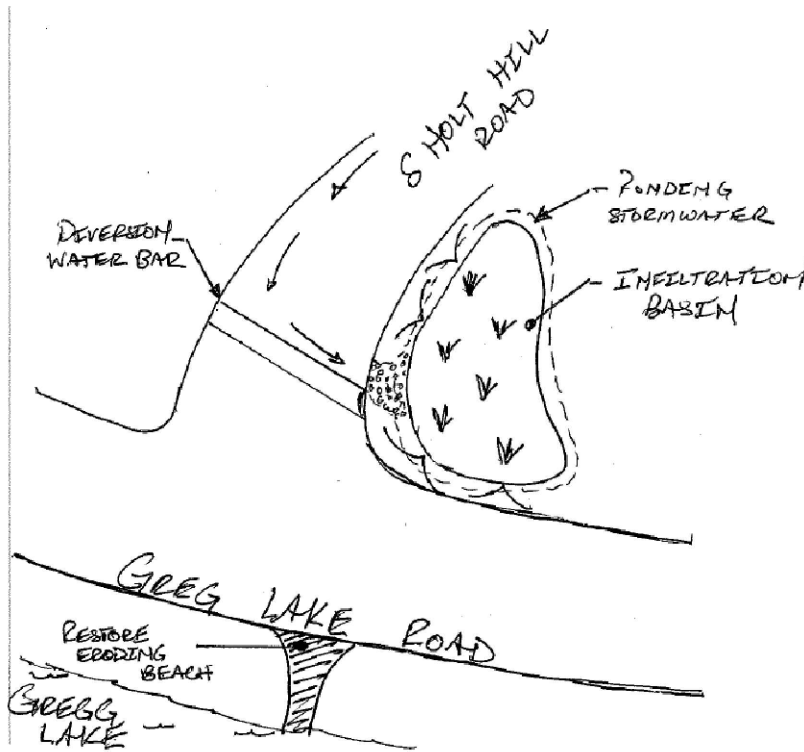
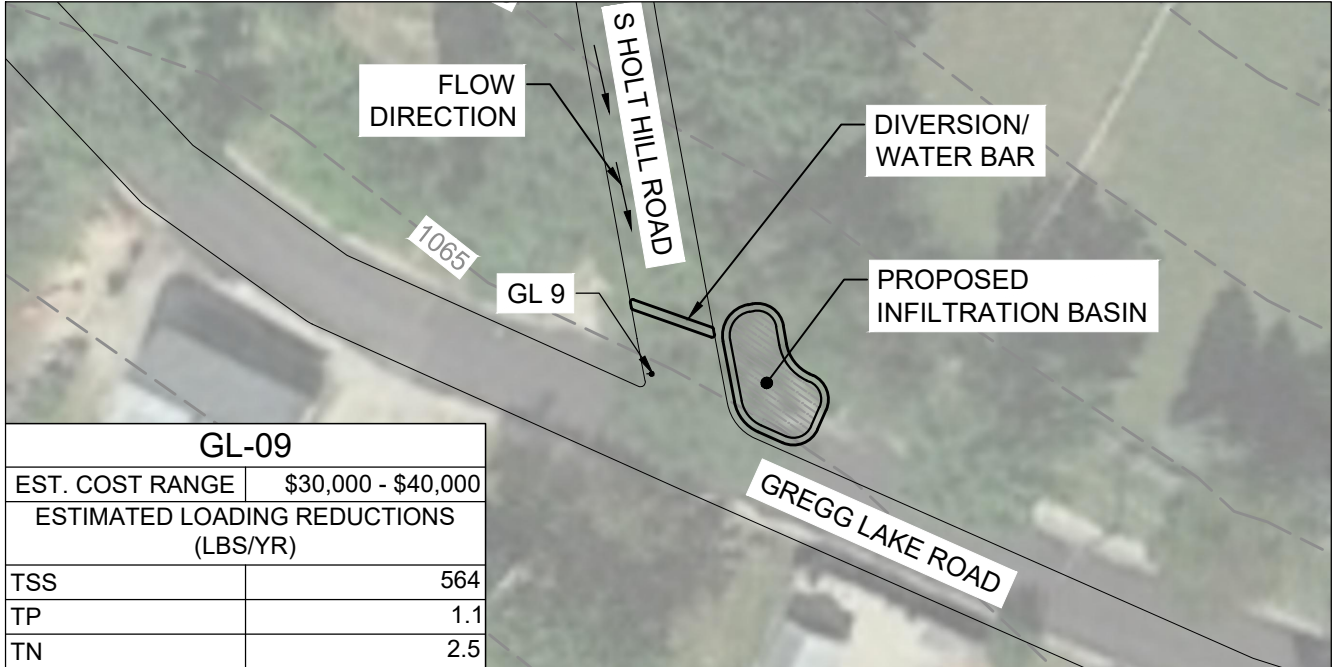

**DRAINAGE DIVERSION & INFILTRATION BASIN DIAGRAM**

NOT TO SCALE

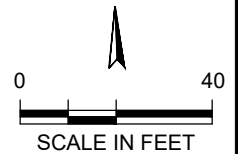

Project Number:  
**18116**

Sheet Number:  
**2 of 8**

Prepared For:  
Town of Antrim  
66 Main Street  
Antrim, NH 03440  
Phone: (603) 588-6785  
Fax: (603) 588-2969



Plan Set:  
**10% CONCEPTUAL BMP'S  
GREGG LAKE EROSION CONTROL  
ANTRIM, NEW HAMPSHIRE**

Plan Title:  
**S HOLT HILL ROAD & GREGG LAKE ROAD (GL-09)**

**Horsley Witten Group, Inc.**  
Sustainable Environmental Solutions  
www.horsleywitten.com  
90 Route 6A  
Sandwich, MA 02563  
508-833-6600 voice  
508-833-3150 fax

Date: JULY 2019  
Designed By: GSG  
Drawn By: GSG  
Checked By: RB



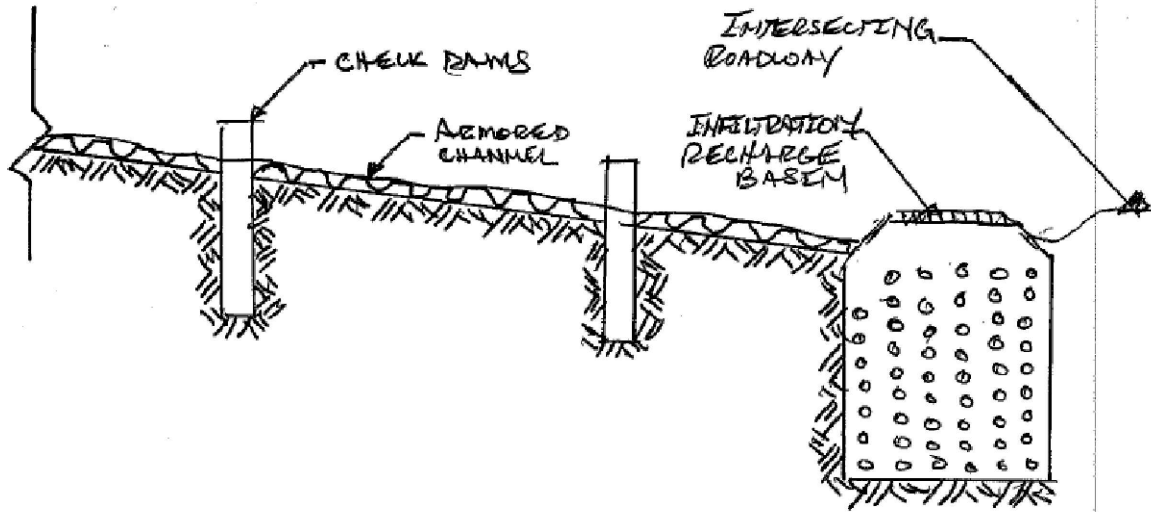
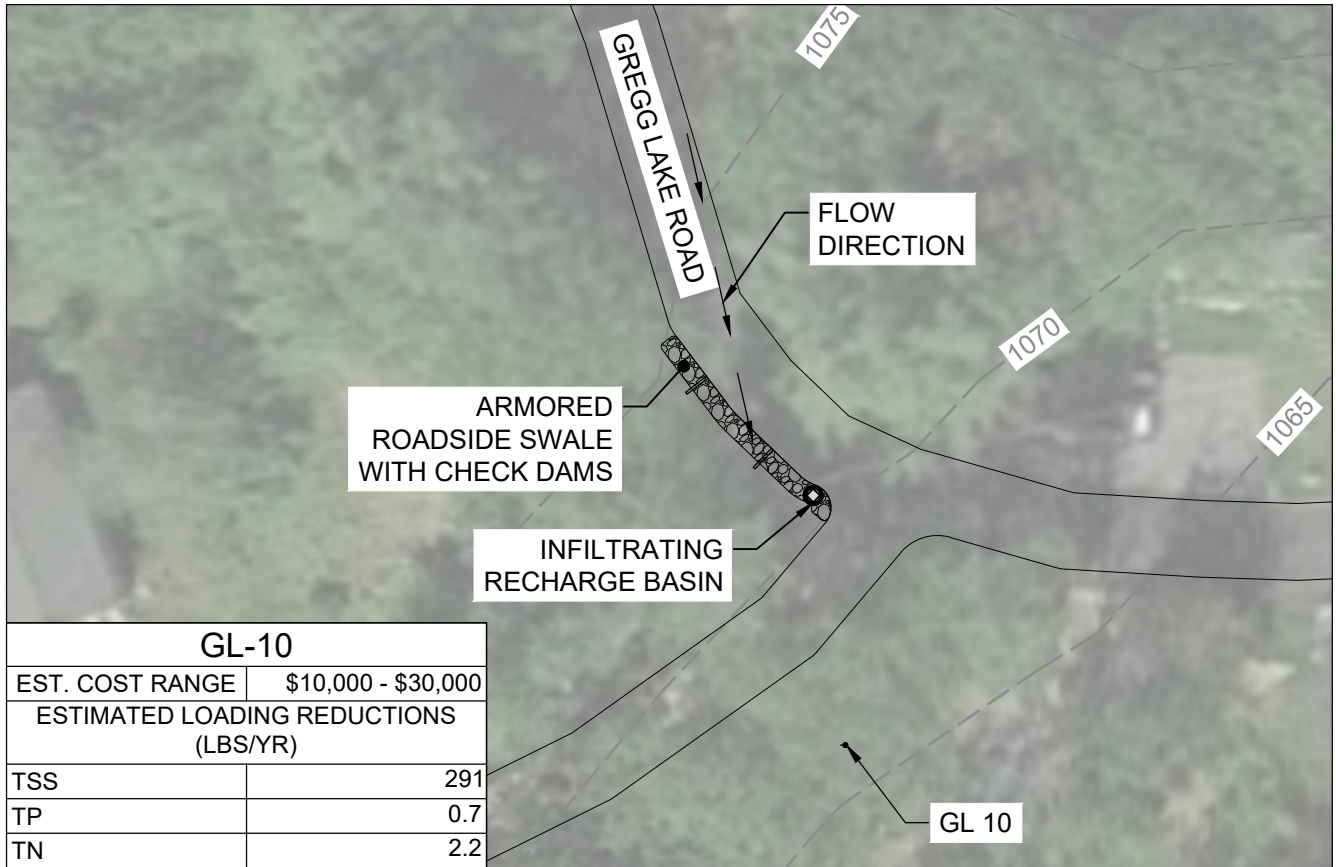

**ARMORED CHANNEL W/ CHECK DAMS**

NOT TO SCALE



Project Number:  
**18116**

Sheet Number:  
**3 of 8**

Prepared For:  
Town of Antrim  
66 Main Street  
Antrim, NH 03440  
Phone: (603) 588-6785  
Fax: (603) 588-2969



Plan Set:  
**10% CONCEPTUAL BMP'S  
GREGG LAKE EROSION CONTROL  
ANTRIM, NEW HAMPSHIRE**

Plan Title:  
**GREGG LAKE DRIVE (GL-10)**

**Horsley Witten Group, Inc.**  
Sustainable Environmental Solutions  
www.horsleywitten.com  
90 Route 6A  
Sandwich, MA 02563  
508-833-6600 voice  
508-833-3150 fax



Date: JULY 2019	Designed By: GSG	Drawn By: GSG	Checked By: RB
--------------------	---------------------	------------------	-------------------

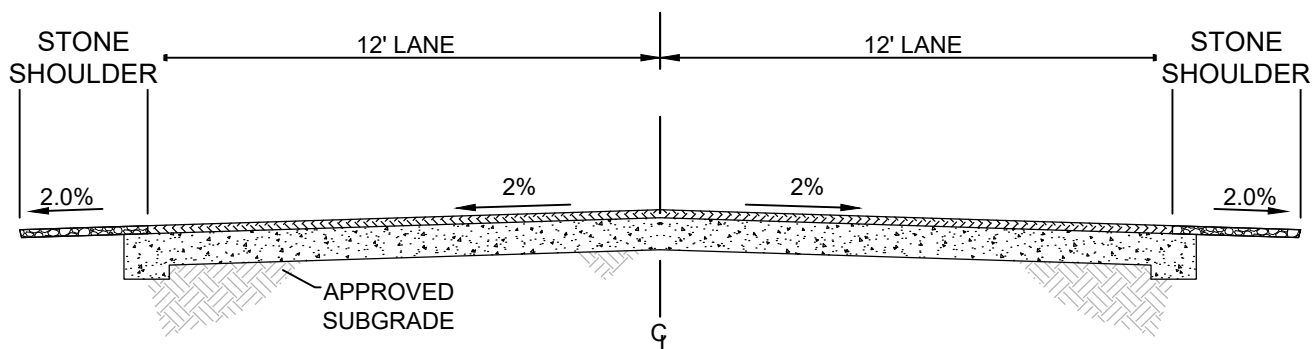
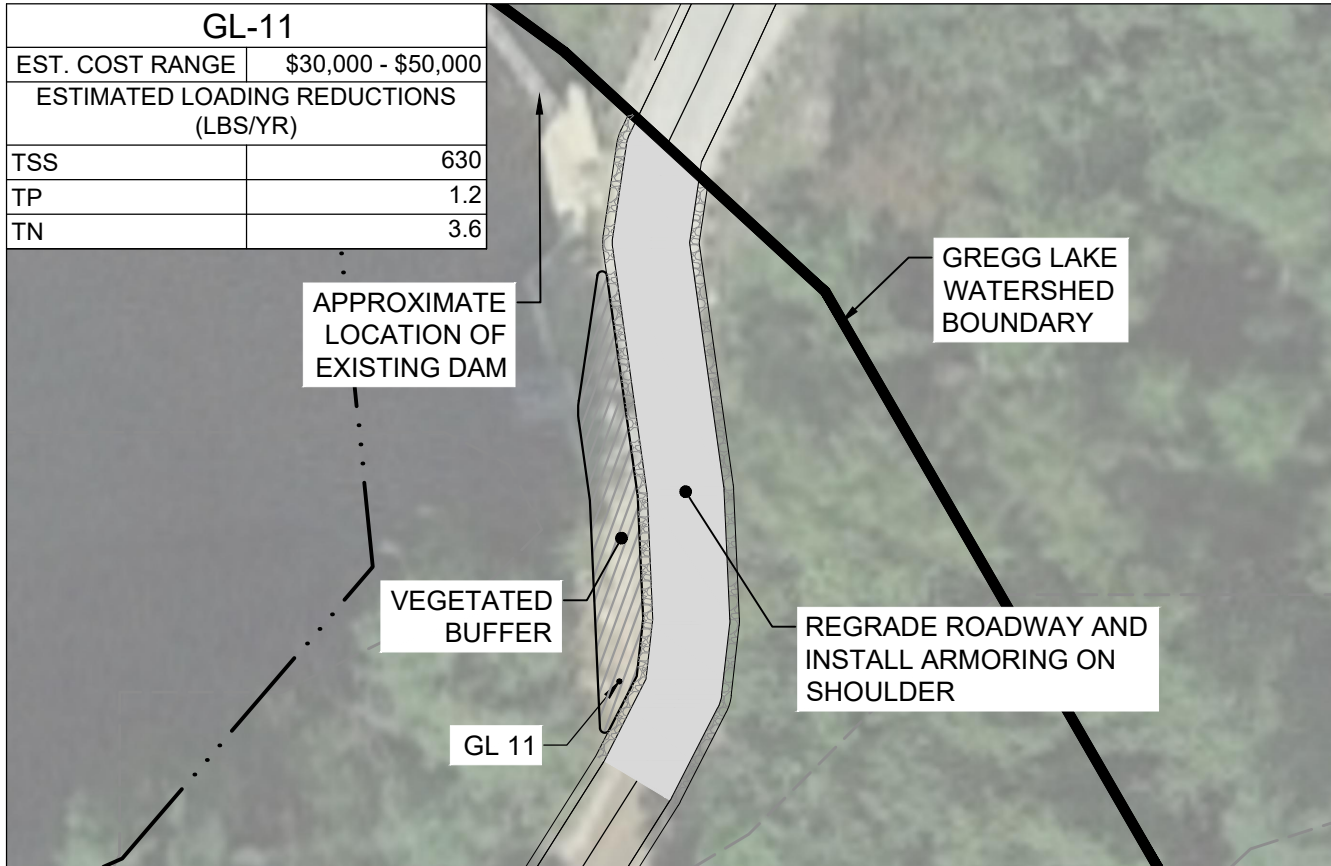

**TYPICAL 2-LANE ROADWAY CROSS SECTION**  
**CROWNED-OPEN SECTION**  
 NOT TO SCALE

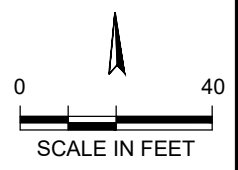

Project Number: <b>18116</b>	Prepared For: Town of Antrim 66 Main Street Antrim, NH 03440 Phone: (603) 588-6785 Fax: (603) 588-2969		Plan Set: <b>10% CONCEPTUAL BMP'S                  GREGG LAKE EROSION CONTROL                  ANTRIM, NEW HAMPSHIRE</b>	<b>Horsley Witten Group, Inc.</b> Sustainable Environmental Solutions www.horsleywitten.com 90 Route 6A Sandwich, MA 02563 508-833-6600 voice 508-833-3150 fax
Sheet Number: <b>4 of 8</b>	Plan Title: <b>WHITE BIRCH POINT ROAD TO                  GREGG LAKE DAM OUTLET (GL-11)</b>		Date: JULY 2019 Designed By: GSG Drawn By: GSG Checked By: RB	



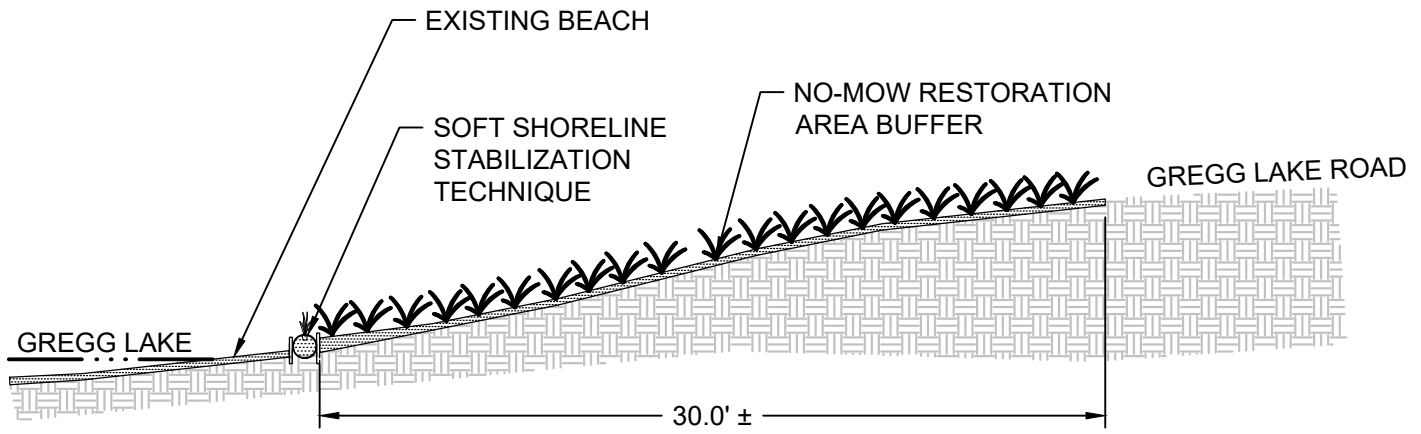
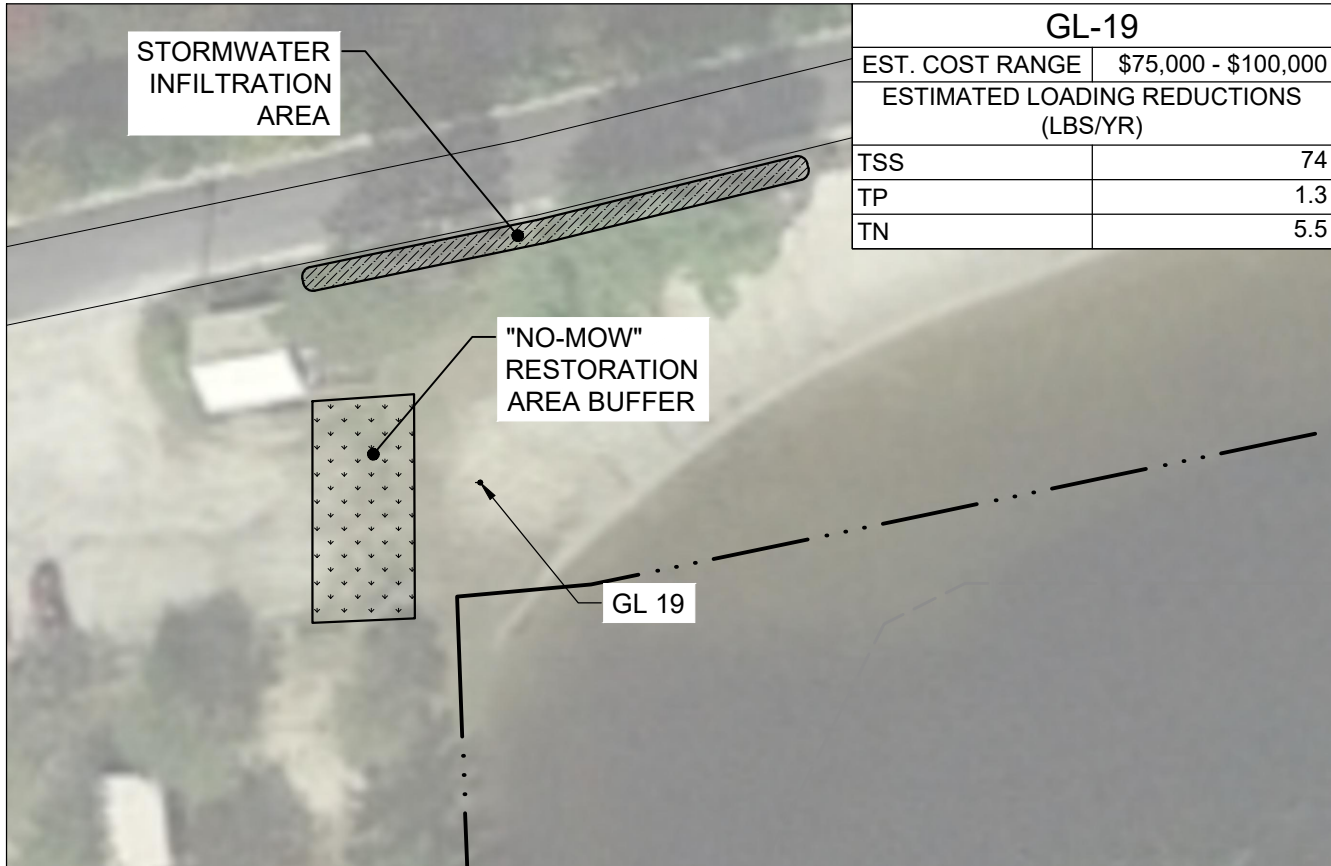

**RESTORATION AREA CROSS SECTION**  
NOT TO SCALE

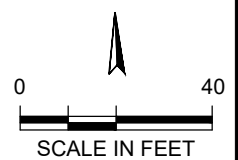

Project Number:  
**18116**

Sheet Number:  
**5 of 8**

Prepared For:  
Town of Antrim  
66 Main Street  
Antrim, NH 03440  
Phone: (603) 588-6785  
Fax: (603) 588-2969



Plan Set:  
**10% CONCEPTUAL BMP'S  
GREGG LAKE EROSION CONTROL  
ANTRIM, NEW HAMPSHIRE**

Plan Title:  
**PUBLIC BEACH AND BOAT LAUNCH (1) (GL-19)**

**Horsley Witten Group, Inc.**  
Sustainable Environmental Solutions  
www.horsleywitten.com  
90 Route 6A  
Sandwich, MA 02563  
508-833-6600 voice  
508-833-3150 fax

Date: JULY 2019  
Designed By: GSG  
Drawn By: GSG  
Checked By: RB



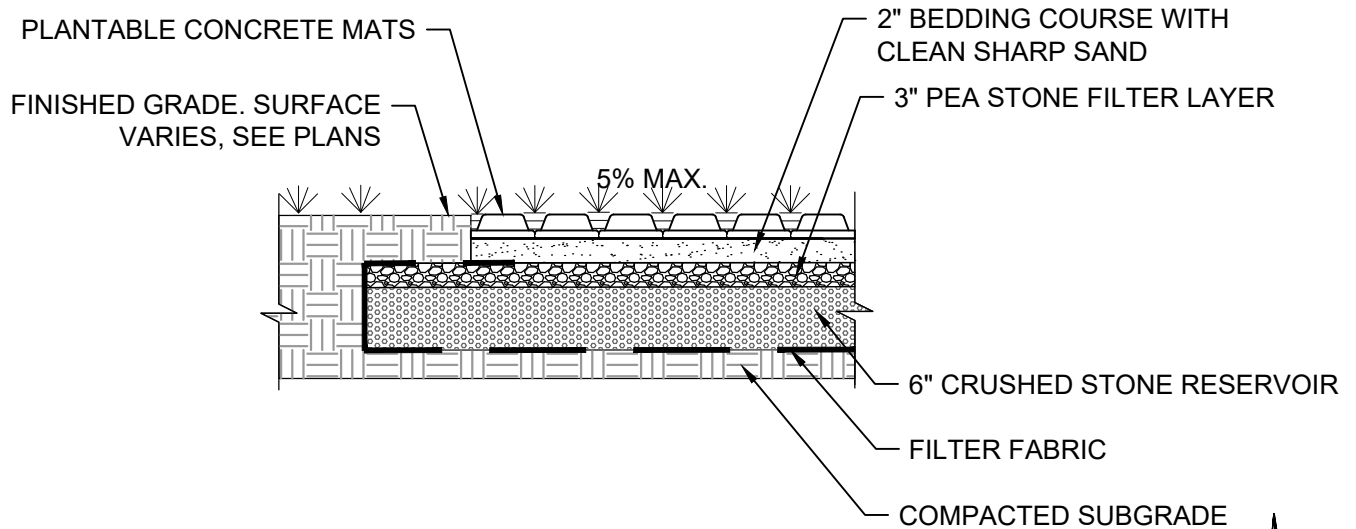
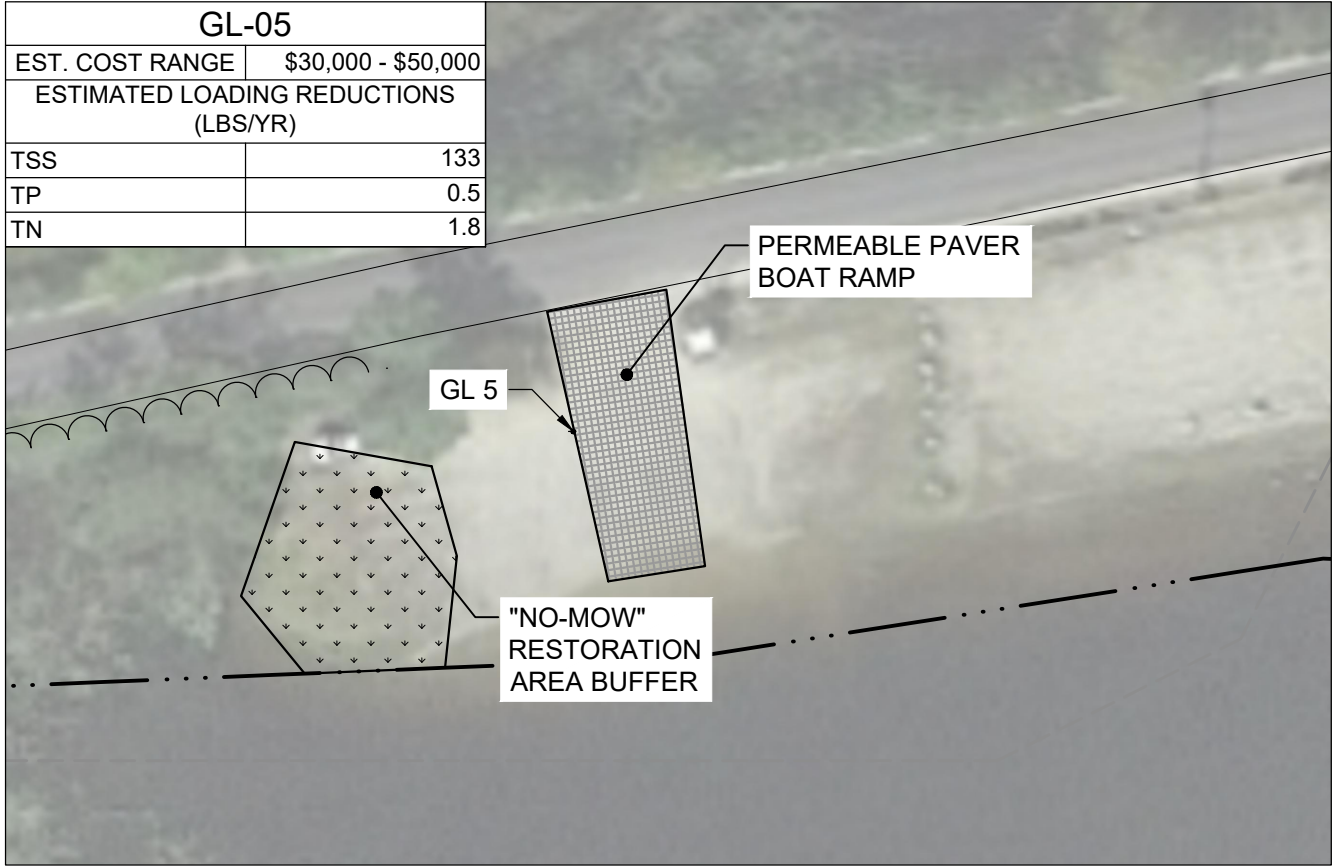

**PERMEABLE PAVER DETAIL**  
NOT TO SCALE



Project Number:  
**18116**

Sheet Number:  
**6 of 8**

Prepared For:  
Town of Antrim  
66 Main Street  
Antrim, NH 03440  
Phone: (603) 588-6785  
Fax: (603) 588-2969



Plan Set:  
**10% CONCEPTUAL BMP'S  
GREGG LAKE EROSION CONTROL  
ANTRIM, NEW HAMPSHIRE**

Plan Title:  
**PUBLIC BEACH AND BOAT LAUNCH (2) (GL-05)**

**Horsley Witten Group, Inc.**  
Sustainable Environmental Solutions  
www.horsleywitten.com  
90 Route 6A  
Sandwich, MA 02563  
508-833-6600 voice  
508-833-3150 fax



Date: JULY 2019	Designed By: GSG	Drawn By: GSG	Checked By: RB
--------------------	---------------------	------------------	-------------------

GL-02, GL-03, GL-04, GL-14, GL-15	
EST. COST RANGE	\$145,000 - \$230,000
ESTIMATED LOADING REDUCTIONS (LBS/YR)	
TSS	10,832
TP	4.8
TN	9.8

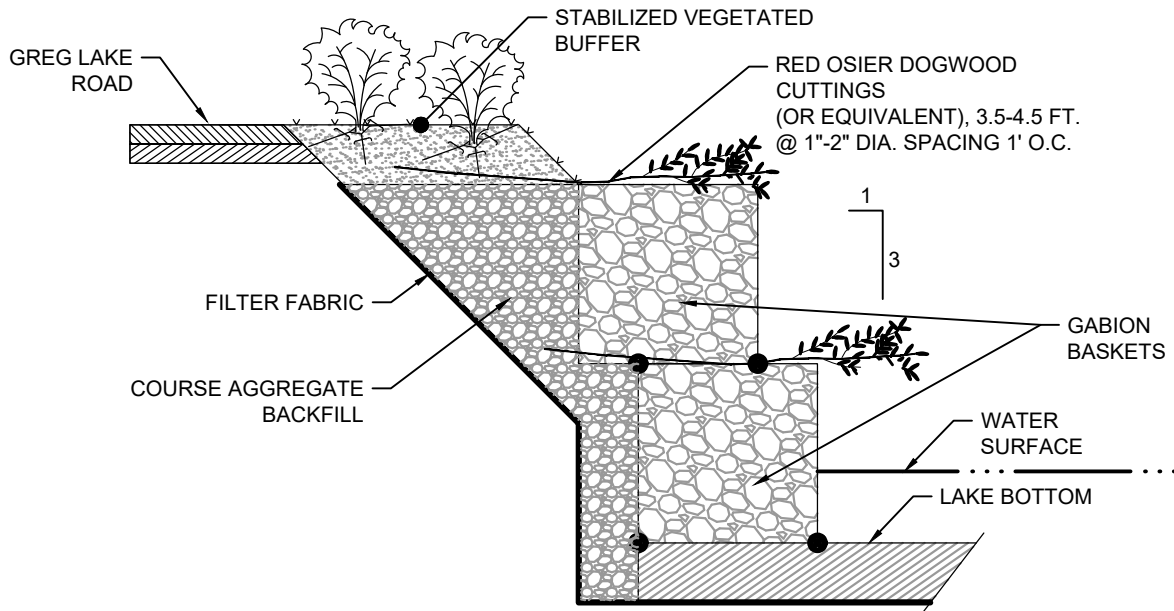
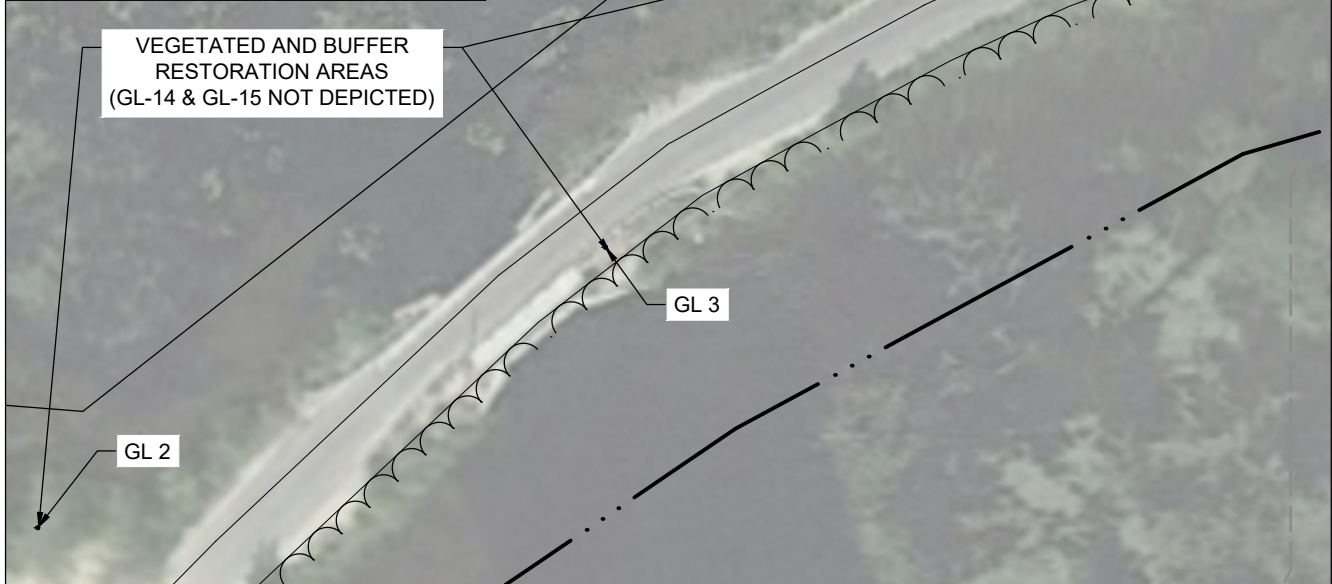

**GABION WALL WITH VEGETATED BUFFER**  
NOT TO SCALE

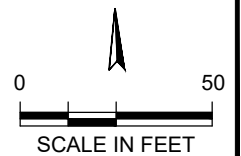

Project Number:  
**18116**

Sheet Number:  
**7 of 8**

Prepared For:  
**Town of Antrim**  
66 Main Street  
Antrim, NH 03440  
Phone: (603) 588-6785  
Fax: (603) 588-2969



Plan Set:  
**10% CONCEPTUAL BMP'S  
GREGG LAKE EROSION CONTROL  
ANTRIM, NEW HAMPSHIRE**

Plan Title:  
**AREA #7 - GREGG LAKE ROAD BUFFERS**

**Horsley Witten Group, Inc.**  
Sustainable Environmental Solutions  
www.horsleywitten.com  
90 Route 6A  
Sandwich, MA 02563  
508-833-6600 voice  
508-833-3150 fax

Date: JULY 2019  
Designed By: GSG  
Drawn By: GSG  
Checked By: RB





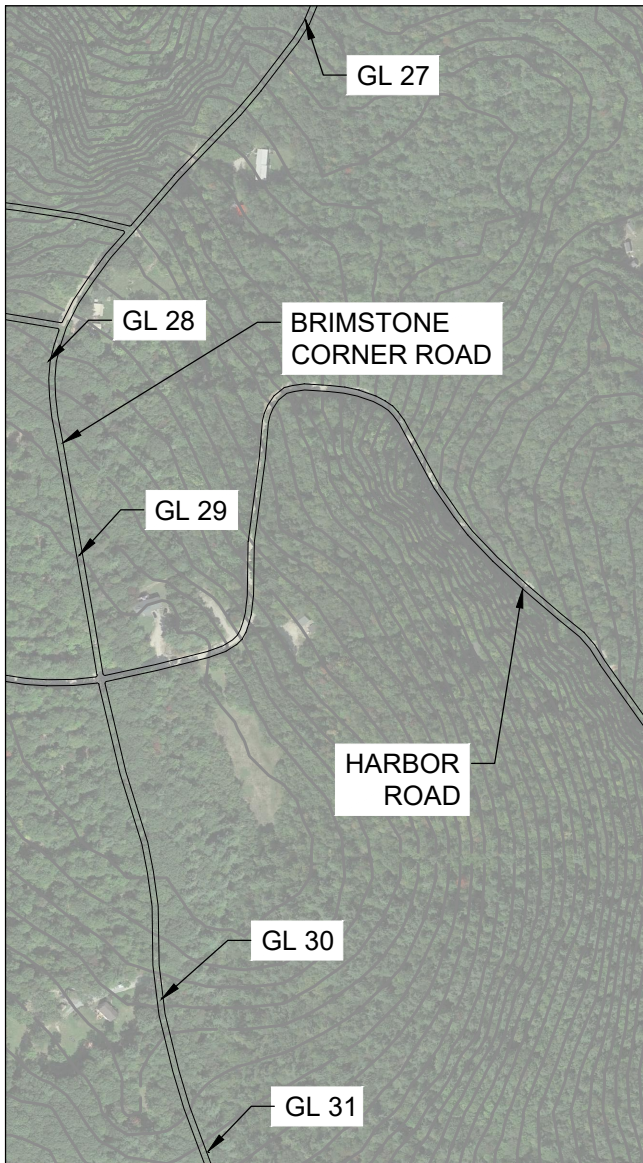

**BRIMSTONE CORNER ROAD**

**ROAD SURFACE MATERIAL**  
THE SURFACE OF UNPAVED ROADS IS COMPOSED OF A MIXTURE OF COURSE AGGREGATES AND FINE MATERIAL (FINES).

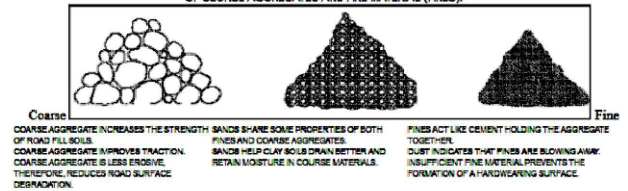

GL-27, GL-28, GL-29, GL-30, GL-31	
EST. COST RANGE	\$55,000 - \$110,000
ESTIMATED LOADING REDUCTIONS (LBS/YR)	
TSS	2,676
TP	3.2
TN	7.2

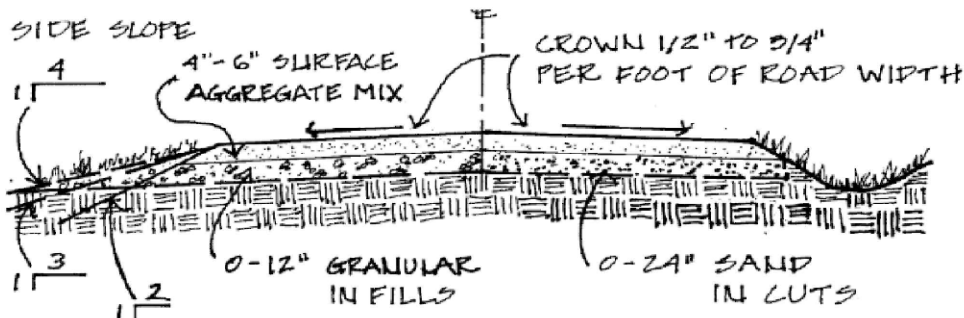

(Source: MA Unpaved Road BMP Manual, 2001)

**RE-CROWNING CROSS SECTION**

NOT TO SCALE

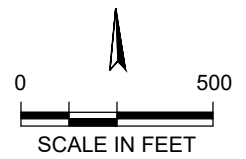

Project Number:  
**18116**

Sheet Number:  
**8 of 8**

Prepared For:  
Town of Antrim  
66 Main Street  
Antrim, NH 03440  
Phone: (603) 588-6785  
Fax: (603) 588-2969



Plan Set:  
**10% CONCEPTUAL BMP'S  
GREGG LAKE EROSION CONTROL  
ANTRIM, NEW HAMPSHIRE**

Plan Title:  
**AREA #10 - BRIMSTONE CORNER ROAD**

**Horsley Witten Group, Inc.**  
Sustainable Environmental Solutions  
www.horsleywitten.com  
90 Route 6A  
Sandwich, MA 02563  
508-833-6600 voice  
508-833-3150 fax

Date: JULY 2019  
Designed By: GSG  
Drawn By: GSG  
Checked By: RB